



# COMPLIANCE BD LTD.

One Stop Engineering Solution



NIRAPON

200+ Projects accomplished

40+ Skilled Engineers

12+ Years Experience

MEMBER



Enlisted Supplier & Consultancy Firm (Fire & Electrical Safety)



Enlisted Supplier & Construction Firm



FIRE DETECTION



FIRE PROTECTION



GAS SUPPRESSION



FOAM SUPPRESSION



PASSIVE FIRE



CIVIL CONSTRUCTION



CONSULTANCY



SUPPORT SERVICES



## Global Partners:



UK



USA



UAE



USA



USA



UK



UK



Germany



**Compliance BD Ltd.** is one of the leading and fastest-growing companies working in Fire Safety Solutions, MEP Projects, and Civil Construction. We have **12 years of experience** in the provision of Fire Standpipe Systems, Fire Detection and Alarm Systems, Fire Sprinkler Systems, Fire Suppression, Fire Separation, and Fire Door Solutions (including assessment, design, supply, installation, commissioning, and maintenance) throughout the country.

**Compliance BD Ltd.** is a one-stop engineering solution enterprise with demonstrated experience in the successful management and implementation of projects nationwide. We specialize in consultancy as well as engineering development services.

We are an authorized and exclusive agent in Bangladesh for well-reputed global manufacturers. **Compliance BD Ltd.** is committed to ensuring that its services and products fully meet customer requirements at all times, with the goal of achieving the highest level of satisfaction. Furthermore, we are dedicated to implementing new technologies through continuous monitoring, measurement, and innovation on a global scale.

Our mission is to contribute to the economic growth of Bangladesh by providing complete engineering solutions for the manufacturing industries, while also prioritizing client satisfaction. To reach our objectives, we continue to deliver our services with full dedication, commitment, and teamwork.

Our team is well-versed in national and international codes, rules, and regulations including NFPA, IEC, IBC, BNBC, and Bangladesh Fire Service & Civil Defense regulations. We have also received **ISO Certification (ISO 9001:2015)** for Sales, Trading & Services of Fire fighting Equipment, and Firefighting-related Training & Consultancy.





## OUR ASSOCIATED BRANDS



## PRODUCTS & SOLUTIONS

- Fire Hydrant / Standpipe System
- Fire Sprinkler System
- Fire Detection and Alarm System
- Fire Suppression System
- Fire Doors, Fire Shutters & Accessories
- Fire Partition / Penetration Systems
- Automatic Smoke and Fire Curtains
- Public Address (PA) Sound System
- Lightning Protection System (LPS)
- Civil Construction & Material Supply
- Training and Consultancy
- Lifting Equipment, Devices, and Tools

## CONSULTING, ASSESSMENT & DESIGN

- ✓ Fire Safety Plan
- ✓ Fire Alarm and Detection System
- ✓ Fire Hydrant / Standpipe and Sprinkler System
- ✓ Fire Suppression System (Gas & Foam)
- ✓ Fire Doors, Fire Shutters & Accessories
- ✓ Automatic Smoke and Fire Curtains
- ✓ Electrical Design and Drawings
- ✓ Civil Design and Drawings
- ✓ Lightning Protection System (LPS)

## INSTALLATION, TESTING & COMMISSIONING

- Fire Alarm and Detection System
- Fire Hydrant / Standpipe System
- Fire Suppression System (Gas & Foam)
- Automatic Smoke and Fire Curtains
- Fire Doors and Fire Shutters
- AMC (Annual Maintenance Contract)



## AUTHORIZED DISTRIBUTOR CERTIFICATE

REFERENCE: NF/SB/COM/01/023  
Date: 01 Jan 2023

### NAFFCO FZCO

Confirms that  
**M/s. COMPLIANCE BD LTD**  
AUTHORIZED DISTRIBUTOR IN THE TERRITORY OF  
BANGLADESH

This certification is applicable for the purpose mentioned above and shall not be construed as to give the distributor any authority or power to act on behalf of NAFFCO FZCO, or to enter into any contracts or to receive and remit money, or to take decisions, and to give any promises, representation, warranties/guarantees on behalf of NAFFCO FZCO, unless otherwise authorized in writing.

This certificate is valid up to 31 Dec 2025.

  
**ALI KHALID AL KHATIB**  
Group Managing Director



## CERTIFICATE OF COMPLETION

Hilti Bangladesh presents this certificate to

### COMPLIANCE BD LTD.

In recognition of professional achievement by successfully completing  
training on Installation of Hilti Firestop products

As  
**Hilti Trained Firestop Specialty Contractor**

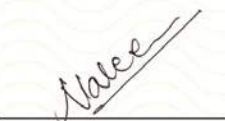
  
**Naleen Kaura**  
General Manager

This certificate is valid till  
28th April, 2026



# FIRE DETECTION & ALARM SYSTEMS

# TRIGA



## Integrated Fire and Voice Control Panel

- UL 864 10th Edition & FM Approved
- Point flexibility of up to 2,100 points
- Supports 2000W per system
- Up to 64,000 watts of power across the network
- Amplifiers supporting 520 Hz low frequency
- Distributed SLC expanders and amplifiers throughout the field
- Option to configure 15 recordable one-minute messages
- Available in red or black cabinet
- Enhanced intelligent network monitoring via graphics
- Secured communication over wired/wireless multifunctional devices
- Seamless integration with BMS

## Intelligent Fire Alarm Panel



Manual Call Point



Smoke Detector



Multi Detector



Heat Detector



Sounder & Strobe



BNBC

# FIRE DETECTION & ALARM SYSTEMS (UL-LISTED)



## Fire Detection Solutions

- Addressable
- Conventional
- Wireless

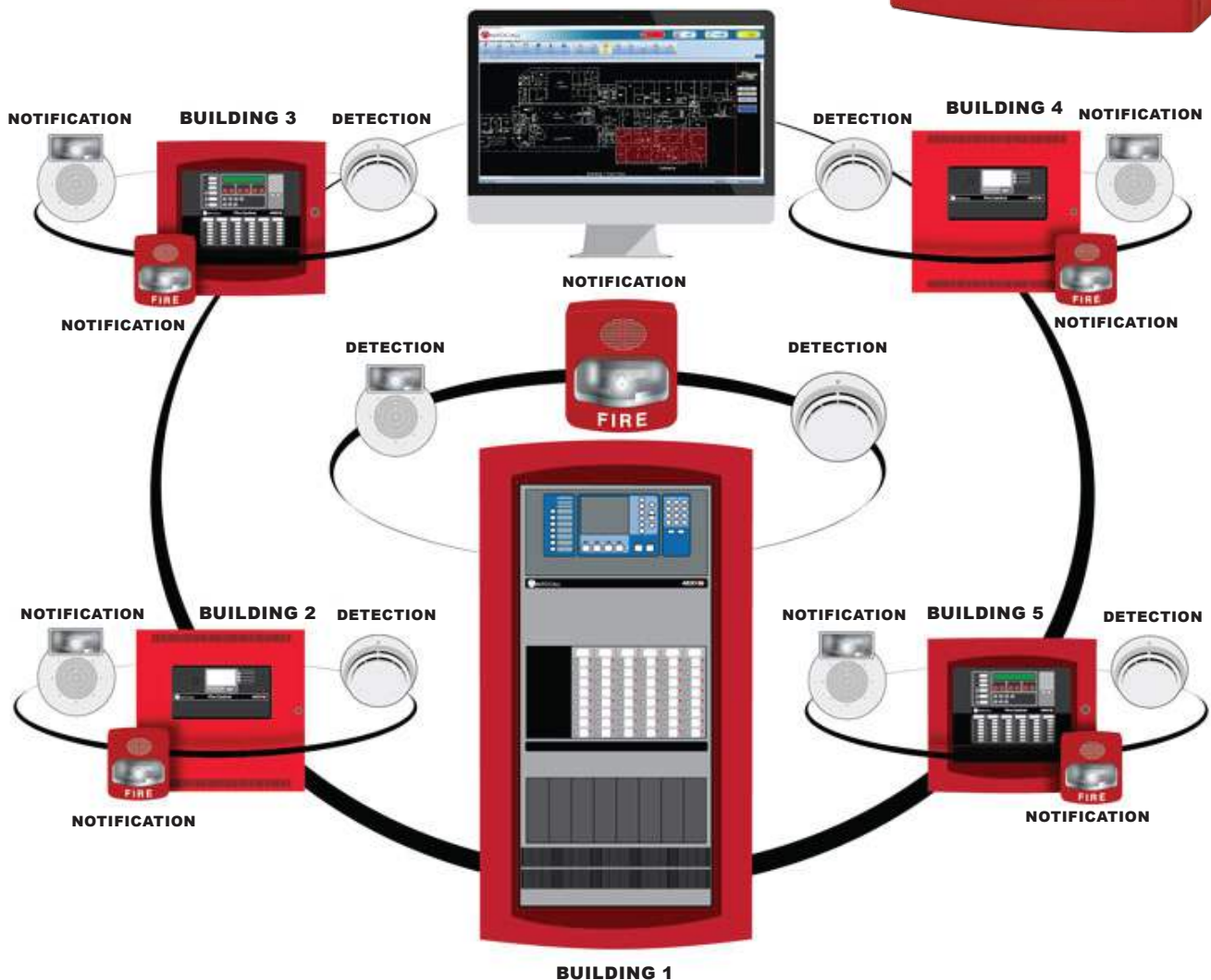



## FIRE ALARM CABLE (UL-LISTED)

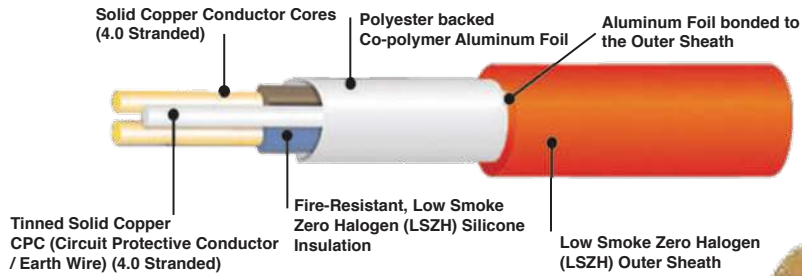

## LINEAR HEAT SENSING (LHS) CABLE (UL-LISTED)

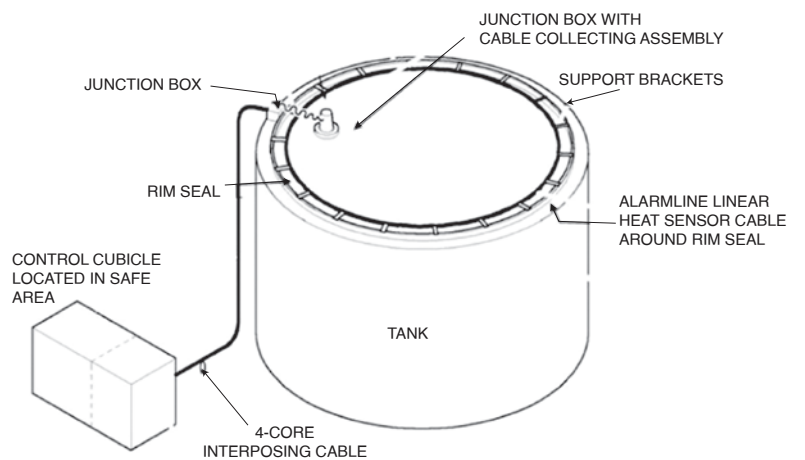
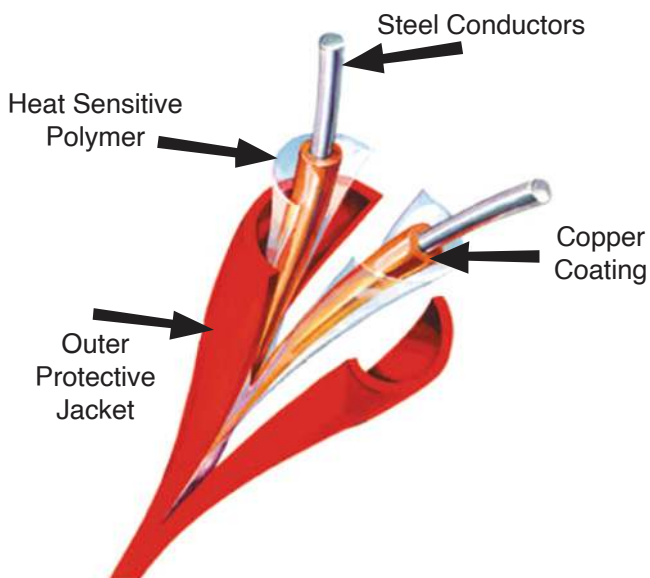

BNBC

**FIRE HYDRANT & SPRINKLER SYSTEM (UL-LISTED)**



Sprinkler



Non-Return Valve



Alarm Check Valve



Pillar Hydrant



Butterfly Valve with Supervisory Switch



Flow Switch



Sprinkler Flexible Hose



Flow Meter



Fire Department Connection



Air Release Valve



Pressure Reducing Valve



Pressure Relief Valve



Y-Strainer



Gate Valve



Fire Hose Set



Landing Valve



BNBC



## PIPE & FITTINGS



UL-Listed Grooved Fittings



UL-Listed Press Fittings



Pipe Fittings (Welded & Threaded)



Supports

## MS PIPE (SCHEDULE 40 – ASTM A53 STANDARD)



BNBC



## UL-LISTED FIRE PUMP (NFPA 20 Compliant)

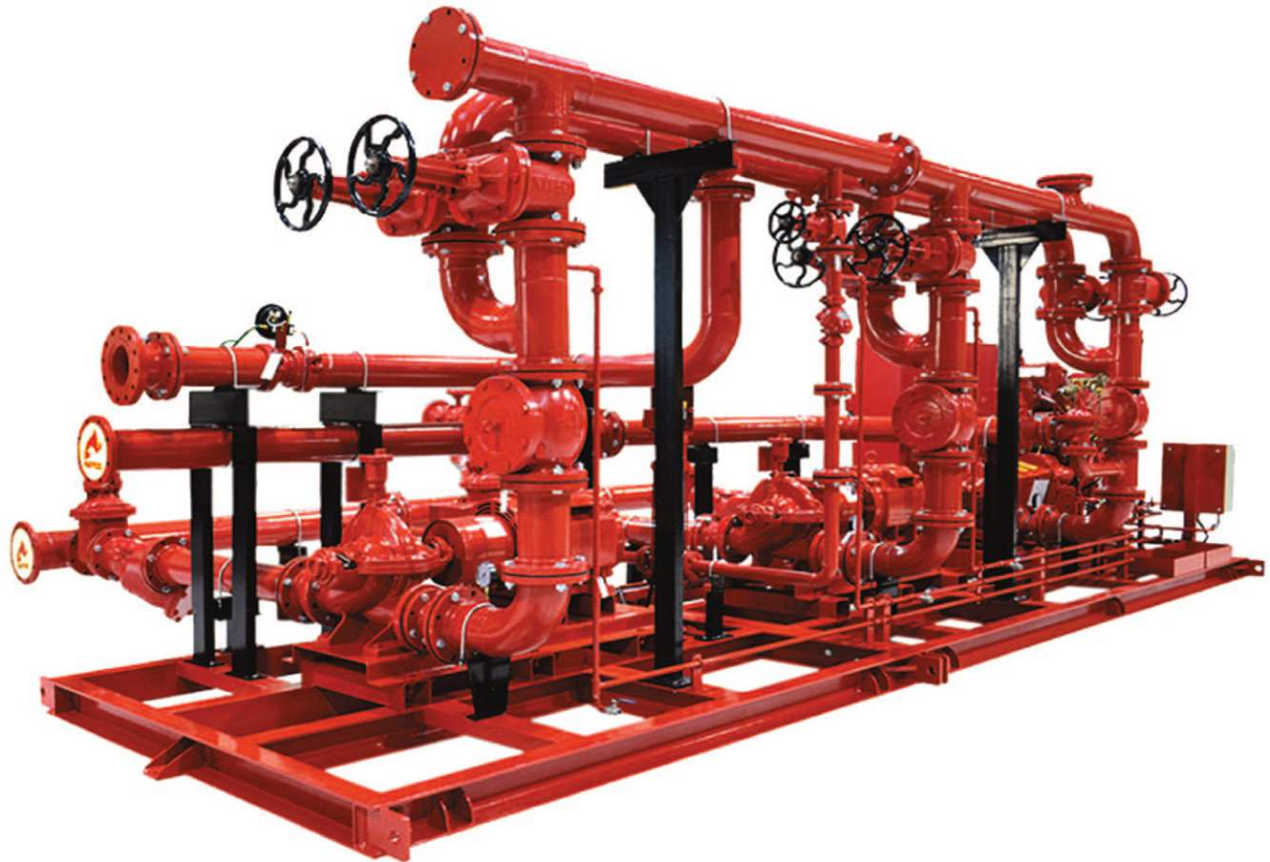

Fire Pump Set



Diesel Engine-Driven Fire Pump



Electric Motor-Driven Fire Pump



Jockey Pump

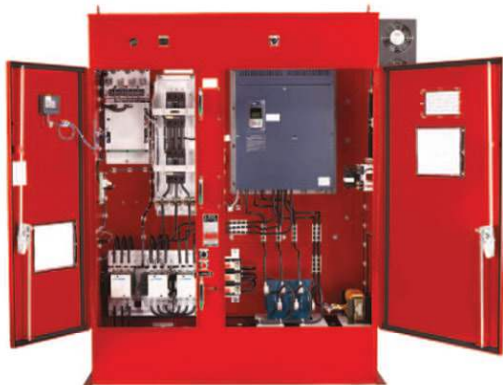

Fire Pump Controller

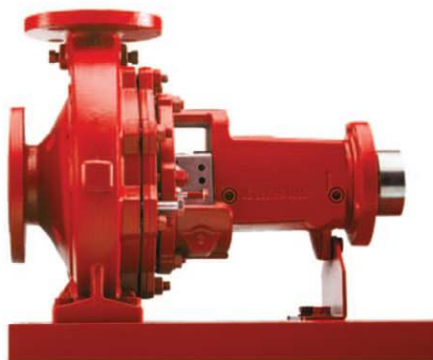

Single-Stage Centrifugal Fire Pump



BNBC



## UL-LISTED VERTICAL TURBINE FIRE PUMP

We offer Vertical Turbine Fire Pumps as space-saving pump room solutions with highly efficient designs. These pumps are engineered for standpipe, sprinkler, chemical mitigation, and hydrant systems. The modular construction ensures complete flexibility in pump selection. Bowls and suction bells are bolted together to allow easier disassembly. Dynamically balanced impellers are secured to the shaft with steel locking. Our pumps comply with NFPA 20, UL, ULC, and FM requirements.

### Features:

- Operates in full compliance with NFPA 20 and UL 448 requirements
- Available in models ranging from 50 to 1500 US GPM
- Driven by electric motors or diesel engines
- Electrical testing capabilities for motors and controllers as per NFPA standards
- Rugged construction for enhanced service life
- Specifically designed for firefighting applications in line with NFPA 20
- Excellent mechanical and hydraulic design for optimized performance

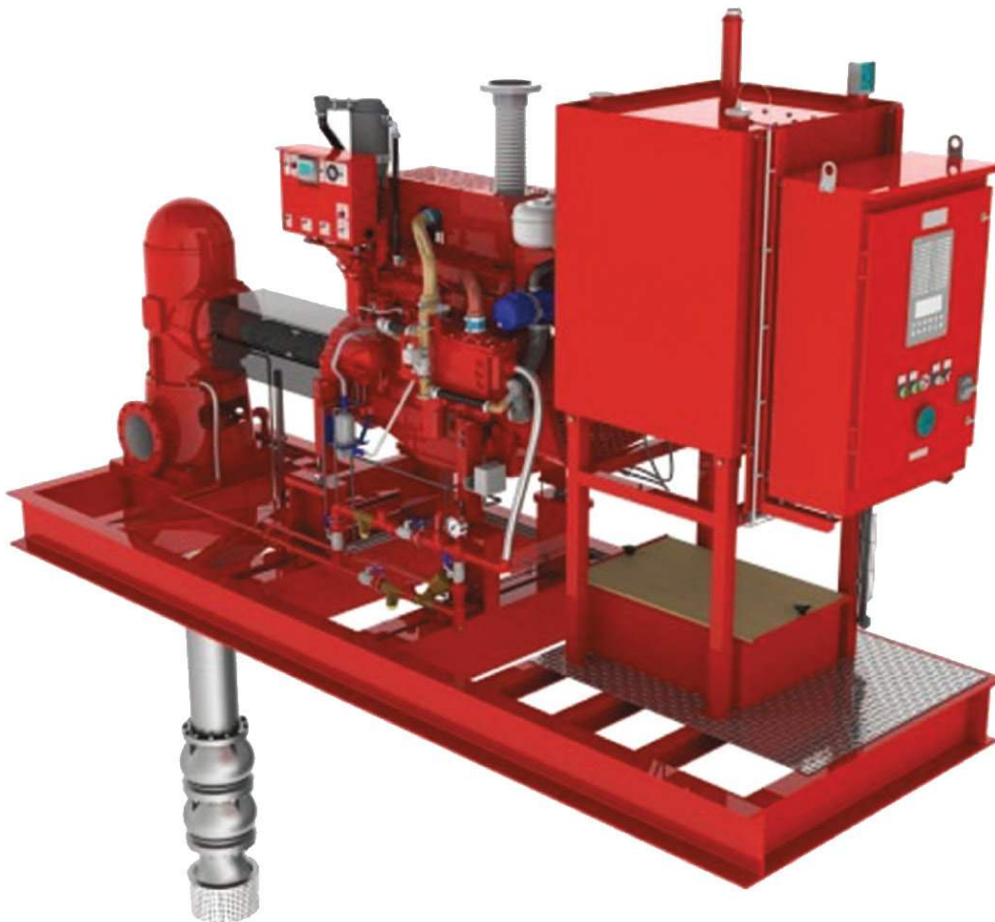

BNBC

**UL LISTED FIRE DOOR & ACCESSORIES**



Single-Leaf Fire Door



Fire-Rated Glass Door



Double-Leaf Fire Door



Magnetic Door Holder



Hinges



Panic Bar



Door Coordinator



Level Trim



Door Closer



## ROLLING SHUTTERS (UL-LISTED)

Our rolling shutters offer fire protection and smooth daily operation. Manual models feature advanced spring systems for easy lifting, even for large shutters. Electric shutters provide top-tier security and can cover wide areas with a single unit. Group controls allow multiple shutters to operate simultaneously. Fire ratings of up to 120 minutes (UL) and 240 minutes (BS) are available.

### Applications:

- Warehouses
- Industrial facilities

### Options:

- Manually operated
- Automatically operated



## FIRE & SMOKE DAMPERS (UL-LISTED)

Modern building projects require advanced safety measures, including fire dampers to maintain the fire resistance of walls, partitions, and floors as mandated by AHJs. Curtain-type dampers prevent fire and smoke from spreading through ducts and are suitable for concrete, brick, or gypsum walls and ceilings, with 2-hour fire ratings. They include 72°C fusible links, with motorized options available for integration with smoke extraction systems.



BNBC

## FIRE & SMOKE CURTAINS (UL-LISTED)

We provide fire and smoke curtains that are used when it is necessary to create a temporary barrier within an opening to seal off the area affected by fire. Our curtain systems automatically descend and prevent the spread of fire and smoke from one area to another. They are also designed to allow safe access to protected escape routes without compromising fire resistance.



### Application :

1. Elevators and Elevator Lobbies
2. Warehouses
3. Escalators and Staircases
4. Corridors and Escape Routes



## LIFT LANDING DOOR



BNBC

## FIRE RETARDANT PAINT (UL-LISTED)

Fire retardant paint protects the structural components of your building during a fire. Our range of paint can be applied to steel structures, concrete, and more, offering a high level of protection. We supply UL-listed fire retardant coatings that can protect structural elements for up to 4 hours.

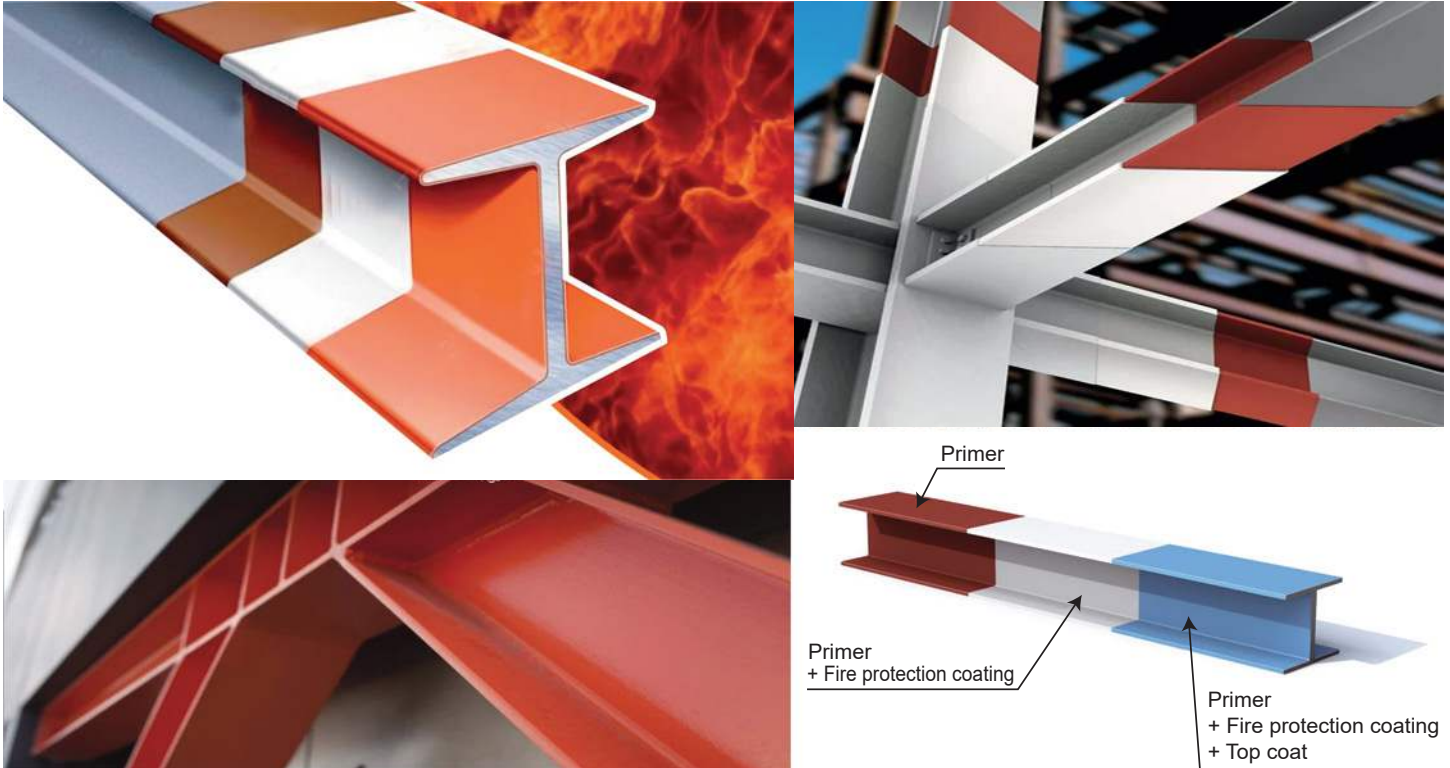

## WHAT IS FIREPROOFING

All materials weaken when exposed to high temperatures. For steel, it is well-established that at 550°C, hot-rolled structural steel retains only about 60% of its strength compared to its room temperature performance. This has led to the common assumption that 550°C is the maximum (limiting) temperature a steel structure can withstand before failing or collapsing.

### Types of Fireproofing

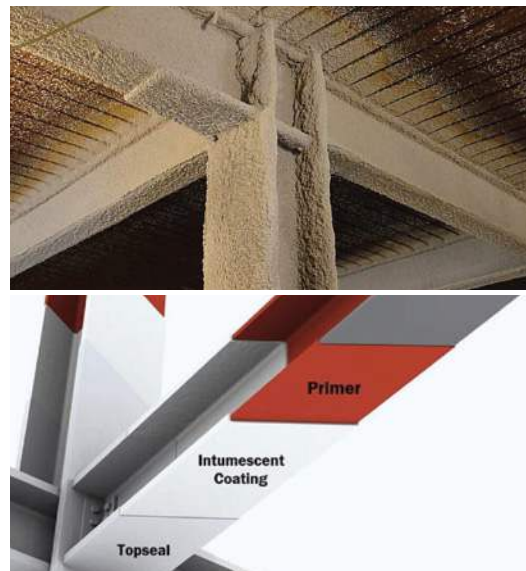
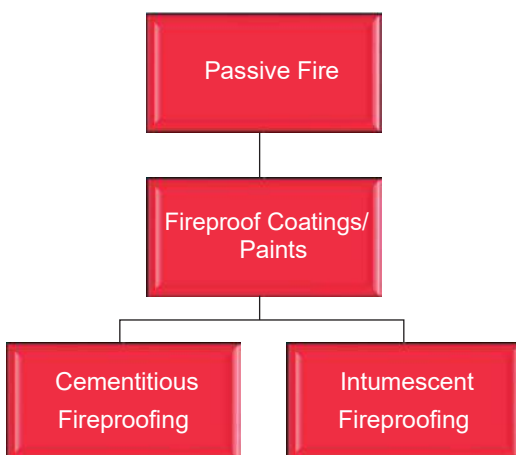

# LIGHTNING PROTECTION SYSTEM (LPS)

We specialize in the complete design, supply, and installation of Lightning Protection Systems (LPS) for industrial, commercial, and residential buildings. Our solutions include both conventional and Early Streamer Emission (ESE) systems, ensuring maximum protection against lightning strikes. By using internationally certified components and expert engineering, we safeguard your structures, equipment, and lives by effectively channeling lightning energy to the ground.



Our Lightning Protection Systems are designed to safely capture and discharge lightning strikes using advanced components such as ESE air terminals, high-voltage shielded cables, copper down conductors, grounding rods, and strike recorders. Our system effectively channels lightning energy from the rooftop to the ground, protecting buildings and occupants from electrical damage. Ideal for residential, commercial, and industrial structures, our setup ensures international safety compliance and long-term reliability.

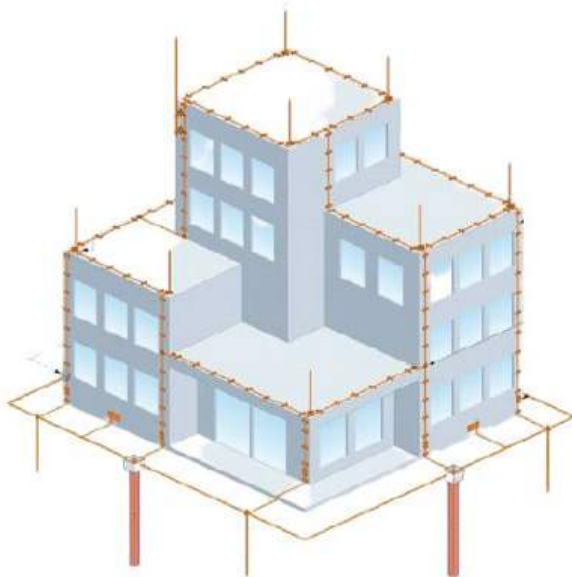
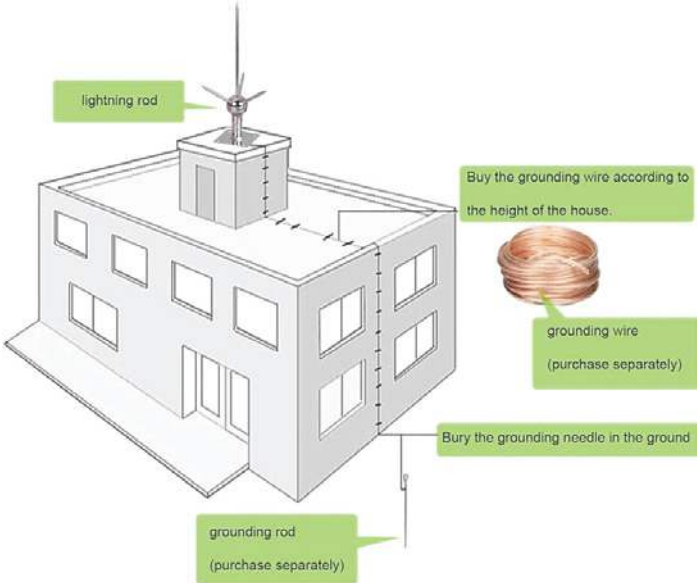

Early Streamer Emission Method LPS

Conventional Method LPS



# FIRESTOP AND FIRE PROTECTION SYSTEM



Germany

Hilti, a Germany-based brand, offers UL-listed passive fire protection products that prevent the spread of fire, smoke, and gases. Trusted worldwide for innovation and reliability, **we are an authorized distributor** providing certified Hilti solutions for code-compliant, long-term building safety.



Firestop Sleeve



Firestop Foam



Firestop Speed Sleeve



Firestop Collars (US)



Firestop Mortar



Firestop Endless Wrap Strips



CFS-SP SIL Silicone-Based Joint Sealant Spray



# PA SYSTEM

Nova is a UK-based brand offering high-quality PA system products known for reliability and performance. Ideal for commercial, industrial, and public spaces, Nova ensures clear sound distribution. **We are the sole authorized distributor**, delivering genuine products with expert technical support.



Horn Speaker



Fashion Speaker



Professional Speaker



PA Amplifier



Wall-Mount Speaker (with Bluetooth option)



Outdoor Speaker



Professional Speaker



Indoor Column Speaker



# PUMP



Liberty is a USA-based leading pump manufacturer, renowned for its innovative and energy-efficient pumping solutions. Serving a wide range of applications including water supply, HVAC, and industrial processes, Liberty products are trusted globally for their quality, reliability, and performance.



Submersible Groundwater Pump



Submersible Wastewater Pump



Horizontal Split Case Pump



Inline Single-Stage Pump



Booster Pump Set



End-Suction Pump



## FOAM BASED SUPPRESSION SYSTEM

We offer foam-based suppression systems that use specialized foam agents to extinguish fires by smothering flames and preventing re-ignition. Our solutions are especially effective against flammable liquid and volatile substance fires, creating a protective barrier that cuts off oxygen and cools the fire.

### Applications:

1. Flammable Liquids
2. Marine Applications
3. Industrial Facilities
4. Commercial Kitchens

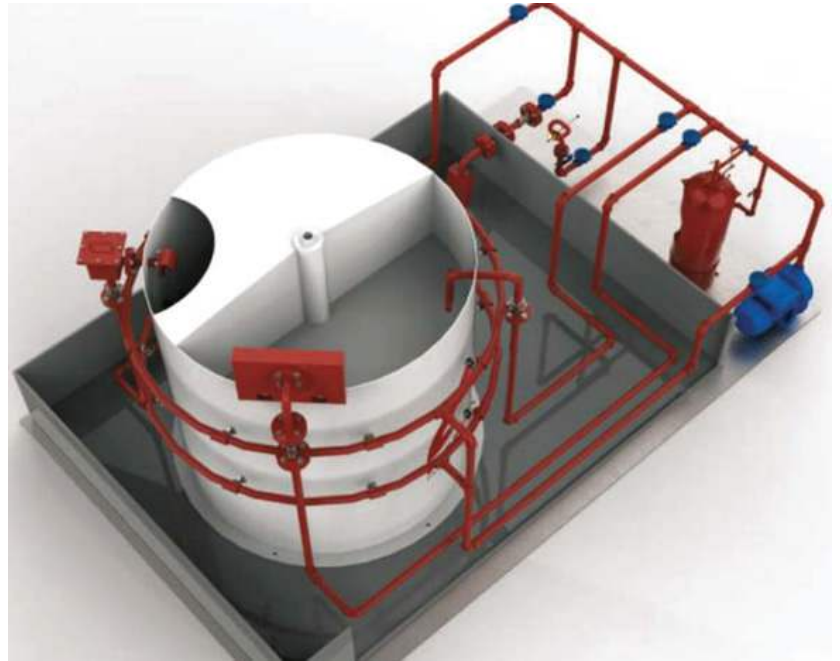

## GAS-BASED SUPPRESSION SYSTEM

Our gas-based suppression systems are designed to extinguish fires by reducing oxygen levels, cooling flames, or disrupting the combustion process. Ideal for areas with sensitive equipment, we provide effective fire protection without the risk of water damage or extensive clean-up.

### Applications

1. Data Centers
2. Telecommunications Facilities
3. Electrical Switchgear / Control Rooms

### Clean Agent Gases:

- FM-200 (HFC-227ea)
- Novec 1230
- Inergen (IG-541)
- CO<sub>2</sub> (Carbon Dioxide)
- Aerosol-Based
- DLP-Based

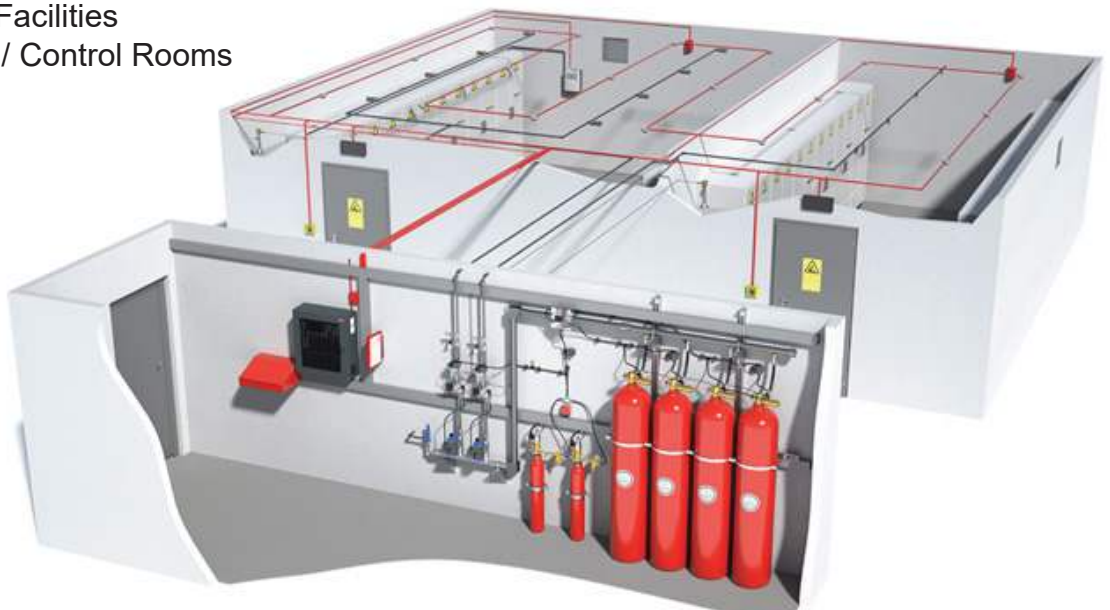

BNBC



## SOME OF OUR APPROVED PROJECTS



SL.	Company Name	RSC ID / ACCORD ID
1.	<b>YUNUSCO (BD) Ltd.</b> Adamjee EPZ, Shiddhirganj, Narayanganj-1431	RSC & Alliance
2.	<b>Delicate Garments Ltd.</b> Fulbari, Savar	RSC
3.	<b>Oxford Shirts Ltd.</b> South Salna, Gazipur	ELEVATE
4.	<b>KC Lingerie Ltd. (Knit Concern Group)</b> Water Works Road, Godnail, Narayanganj	ACCORD
5.	<b>That's It Fashion Ltd. (previously Peak Apparels)</b> <b>Ha-Meem Group</b> Vogra, Jaydevpur, Gazipur, Dhaka	ACCORD
6.	<b>Apparel Export Ltd.</b> Darusalam, Mirpur	RSC
7.	<b>Abanti Colour Tex Ltd. (Crony Group)</b> Shashongaon, Enayetnagar, Fatullah, Narayanganj	RSC
8.	<b>Unisense Apparels Ltd.</b> Anchor Road, Sreepur, Gazipur	ACCORD
9.	<b>Unisense Apparels Ltd. (Extension)</b> Anchor Road, Sreepur, Gazipur	RSC
10.	<b>D&amp;S Pretty Fashion's Ltd.</b> South Salna, Gazipur.	RSC
11.	<b>S.Suhi Industrial Park Ltd.</b> Zamgora, Savar	RSC
12.	<b>Paxar Bangladesh Ltd.</b> DEPZ Old & New Area, Adhipress, Savar	FM Global
13.	<b>T-Design Sweaters Ltd. (Designtex Group)</b> Jorun, Konabari	ACCORD
14.	<b>Shirina Garments &amp; Textile Ltd.</b> Chattogram	Alliance
15.	<b>Glory Industries Ltd.</b> Chattogram	Alliance
16.	<b>Anzir Apparels Ltd. (Unit 02)</b> Dewan Idrisroad, Zirabo	ACCORD
17.	<b>Billah Resources Ltd.</b> Khataldia Squib Road, Nishad Nagar, Tongi	ACCORD
18.	<b>Romo Fashion Today Ltd.</b> Mouchak, Kaliakoir, Gazipur-1751	ACCORD
19.	<b>Max Sweater (BD) Ltd.</b> Borabo, Tarabo, Narayanganj	RSC & Alliance
20.	<b>R-Pac Bangladesh Ltd.</b> Plot No. 38 & 55, AEPZ	Alliance
21.	<b>Turag Garments &amp; Hosiery Mills Ltd.</b> Zirani Bazar, Kashimpur 6260	ELEVATE
22.	<b>MM Knit Wear Ltd.</b> Konabari, Gazipur	RSC
23.	<b>Pretty Sweaters Ltd.</b> Plot # 222, Gacha, Chandona, Gazipur	RSC
24.	<b>Mastrade Int. Garments Ltd.</b> Plot # 72, Bypass Biswa Road,, Mogarkhal, Gazipur	RSC
25.	<b>Parasole Footwear Ltd.</b> Moddho Gazirchat, Ashulia, Savar, Dhaka	ELEVATE

And many more...



**BNBC**



## OUR LEED-CERTIFIED GREEN PROJECTS



### Some of Our LEED-Certified Green Factories:

 **Color & Co Ltd.**  
Mawna, Gazipur

 **Windy Apparels Ltd.**  
Tongi, Gazipur-1710

 **NPM Apparels Ltd.**  
Kapasia, Gazipur, Dhaka.

 **Esprit Apparels Ltd.**  
Gazipur, Dhaka

 **Amanat Shah Woven Dyeing  
& Fabrics Ltd.**  
Panchdona Narsingdi

 **Beximco Garments Building**  
Sarabo, Kashimpur, Gazipur

 **Pretty Composite Textile Ltd.**  
Ashulia, Dhaka

 **Yongtai Industries BD Ltd.**  
Tarabo Muni, Narayanganj





## PROJECT GALLERY



Dhaka Metro Station



Windy Apparels Ltd.



Karnaphuli Tunnel



Colour & Co Ltd.



HS Composite Textiles Ltd.



Esprit Apparels Ltd.



Fashion Pulse Ltd.



Paxar Bangladesh Ltd.

**PROJECT GALLERY**



Chandpur 150MW Combined Cycle Power Plant



Karnaphuli Sportswear Ind. Ltd. (Youngone)



Barapukuria (BPDB) Coal Power Plant



Square Fashions Ltd.



Bhola 225 MW Combined Cycle Power Plant



Apex Footwear Ltd. Unit-2



Tangail Palli Power Generation Ltd.



NPM Apparels Ltd.

## PROJECT GALLERY



United International University (UIU)



Youngone KEPZ



Beximco Industrial Park



Pretty Sweaters Ltd.



Oxford Shirts Ltd. (Pretty Group)



Barishal Silo



Well Composite Kint Ltd.



Titas Sportswear Ind. Ltd. (YoungOne)

**OUR MAJOR CLIENTS (GROUP OF COMPANIES) IN DHAKA**





## OUR MAJOR CLIENTS (GROUP OF COMPANIES) IN DHAKA



## OUR MAJOR CLIENTS (GROUP OF COMPANIES) IN CHATTOGRAM





## CLIENT LIST (DHAKA)

SL	Client	Address	Project Type
1	Dhaka Metro Rail-Dhaka Mass Transit Company Ltd. (DMTCL)	Probashi Kallyan Bhaban (Level-14), Old Elephant Road Eskaton Garden, Dhaka.	Fixed Fire Fighting & Gas Extinguishing System
2	Karnaphuli Tunnel	Anwara Upazila, Chattogram Division, Bangladesh	FM-200 Suppression System and Foam Suppression System .
3	Barapukuria (BPDB) Coal Power Plant	Dudhipur, Durgapur, Parbatipur Upazila, Dinajpur District, Bangladesh	Central Fire Detection System, Fire Protection System & Fire Suppression System
4	Bhola 225 MW Combined Cycle Power Plant (BPDB)	BPDB, Borhanuddin, Bhola, Bangladesh.	Central Fire Detection System, Fire Protection System & Fire Suppression System
5	Chandpur 150MW Combined Cycle Power Plant (BPDB)	Chandpur, Bangladesh	Central Fire Detection System & Fire Protection System & Fire Suppression System
6	Bhairab Power Ltd. (Doreen Power Generations)	Bhairab, Kishoreganj	Central Fire Detection, Protection & Hydrant System.
7	Tangail Palli Power Generation Ltd.	Tangail, Bangladesh.	Central Fire Detection System (CFDS) Fire Protection System (FPS) & Hydrant System
8	BAT (British American Tobacco)	Chattogram, Savar, Dhaka Zone	FPS, FDS, PA, Suppression System & AMC
9	Paxar Bangladesh Ltd.	DEPZ Old & New Area, Adhipress, Savar.	FPS, FDS, PA, Suppression System & AMC
10	BEXIMCO Garments	Sarabo, Kashimpur, Gazipur, Bangladesh	Central Fire Protection System & Sprinkler System
11	Windy Apparels Ltd. (Windy Group)	116, Pager-Morkun Link Road, Tongi, Gazipur, Bangladesh	Central Fire Detection System, Fire Protection System & Sprinkler System
12	Amanat Shah Spinning Mills	Ali Bhaban (5th Floor), 9, Rajuk Avenue, Motijheel C/A, Dhaka-1000, Bangladesh.	Central Fire Detection System & Fire Protection System & Sprinkler System
13	Walton Hi-Tech Industries PLC	Chandra, Kaliakoir, Gazipur	Fire Safety Consultancy
14	Amanat Shah Woven Dyeing & Fabrics Ltd.	Narsingdi, Dhaka.	Central Fire Detection & Fire Curtain
15	ACI Formulations Limited	Bhawal, Rajabari, Gazipur	Central Fire Detection System, Fire Protection System & Sprinkler System
16	ACI Biotech Limited	243, Tripurdi, Aminpur, Sonargaon , P.S, Narayanganj-1440, Bangladesh	Central Fire Detection System
17	Sheraton Dhaka	Kemal Ataturk Avenue, Banani, Dhaka.	AMC of Central Fire Detection System, Fire Protection System & PA System
18	DNCC Banani Super Market	Kemal Ataturk Avenue, Banani, Dhaka.	Central Fire Detection System, Fire Protection System & PA System
19	Turag Garments & Hosiery Mills Ltd.	Zirani Bazar, Kashimpur	Central Fire Detection System
20	Apparels Export Ltd.	2/C, Darussalam road, Mirpur, Dhaka-1216.	Central Fire Detection System & Fire Protection System
21	United International University (UIU)	United City, Madani Ave., Dhaka-1212.	Central Fire Detection System & Fire Protection System
22	Gulshan Center Point (United Group)	Gulshan-2, Dhaka.	Central Fire Detection System & Fire Protection System.
23	Dhanmondi Center Point (United Group)	Dhanmondi, Dhaka.	Central Fire Detection System & Fire Protection System.
24	MA Rashid Hospital (United Group)	Jamalpur	Central Fire Detection System & Fire Protection System.
25	Executive Complex (United Group)	Madani Avenue, United City, Dhaka.	Central Fire Detection System & Fire Protection System.
26	Abanti Colour Tex (Crony Group)	BSCIC, Narayanganj	Central Fire Detection, Protection & Sprinkler System
27	Anzir Apparels Ltd., Unit-2	Dewan Idris Road, Zirabo, Ashulia, Savar, Dhaka.	Central Fire Detection System

## CLIENT LIST (DHAKA)

SL	Client	Address	Project Type
28	Delicate Garments Ltd.	Rajghat, Rajfulbaria, Savar, Dhaka.	Central Fire Protection & Sprinkler System
29	Parasole Footwear Ltd.(Paragon Group)	Gazirchat, Zamgora, Savar	Central Fire Detection, Fire Protection/Standpipe & Fire Door
30	Rising Knit Textiles Ltd. (Rising Group)	Nayadingi (Bus Stand), Sauria, Manikgonj.	Central Fire Detection System, Fire Door & Sprinkler Accessories.
31	R-Pac Bangladesh Packaging Company Ltd.	Adamjee EPZ, Narayanganj	Central Fire Detection System.
32	Uniglory Accessories Ltd.	Mirzapur, Tangail.	Central Fire Detection System.
33	Square Fashions Ltd.	Vogra, Bason Union, Chowrasta, Gazipur.	Central Fire Detection & Alarm System, Central Fire Protection System.
34	Square Apparels Ltd.	Jamirdia, Bhaluka, Mymensingh	Central Fire Detection & Alarm System, Central Fire Protection System.
35	Yester Jeans Ltd.	Adamjee Export Processing Zone	Fire Detection & Alarm System, Fire Protection System
36	Yester Accessories Co.(Bd) Ltd.	Adamjee Export Processing Zone	Fire Detection & Alarm System, Fire Protection System
37	Maruhisa Pacific Co. Ltd.	Rd to Adamjee EPZ, Narayanganj	Fire Protection System (FPS) / Hydrant System and Civil Construction of Pump House and Water Reservoir
38	Pretty Sweaters Ltd. (Pretty Group)	Plot # 222, Gacha, Chandona, Gazipur	Central Fire Detection, Protection & Sprinkler System.Fire Door
39	S. Suhi Industrial Park Ltd.(Pretty Group)	Jamgora, Ashulia, Savar, Dhaka-1349.	Central Fire Detection System, Fire Protection System.
40	Oxford Shirts Ltd.(Pretty Group)	Pretty Square, South Salna, Gazipur.	Central Fire Detection System, Fire Protection System & Fire Sprinkler System.
41	Pretty Composite Knit Ltd.(Pretty Group)	Jamgora, Ashulia, Savar, Dhaka.	Central Fire Detection System & Fire Protection System.
42	D & S Pretty Fashions Ltd.(Pretty Group)	Salna. Gazipur	Central Fire Detection, Fire Protection / Standpipe
43	Remark HB Ltd.	Bausia, Gazaria, Munshiganj-1510	Central Fire Detection System, Fire Protection System & Fire Sprinkler System.
44	Trust Knitwear Industries Ltd.	Indrapur Road, Bhabanipur, Gazipur	Central Fire Detection, Fire Protection (FPS) / Hydrant & Sprinkler System
45	Globex Pharmaceuticals Ltd.	Salbon Road, Masterbari, Gazipur	Central Fire Detection, Fire Protection (FPS) / Hydrant System & Fire Door.
46	Joy Auto Garments Printing Ltd.	BSCIC, Narayanganj	Central Fire Detection System & Fire Protection System & Sprinkler System
47	KC Spinning Ltd.	Godnail, Narayanganj	Central Fire Detection, Fire Protection / Standpipe
48	Knit Concern Ltd.	62, Water Works Road, Godnail, Narayanganj	CFDS, FPS, Sprinkler System, Fire Door, Curtain & Lightning Protection System(LPS)
49	KC Print Ltd.	61, Water Works Road, Godnail, Narayanganj-1400.	Central Fire Detection, Fire Protection (FPS) / Sprinkler System, Fire Door & Curtain
50	KC Apparels Ltd.	BSCIC, Narayanganj	Central Fire Detection, Fire Protection (FPS) / Hydrant System, Fire Door
51	Liz Fashion Industries Ltd. (Lida Textiles & Dying Ltd.)	Shafipur, Kaliakoir, Gazipur.	Central Fire Detection, & Consultancy of Protection, Hydrant & Sprinkler System.
52	MM Knitwear Ltd.	Ambag Road, Nilnagar, Konabari, Gazipur.	Central Fire Detection, Protection, Hydrant, Fire Door & Fire Suppression System.
53	Mamun Knitwear Ltd., Unit-1,2	Konabari, Gazipur.	Central Fire Detection, Protection & Hydrant System.
54	Fashion Pulse Ltd.(Fashion Step Group)	BSCIC Industrial Estate, Tongi	Central Fire Detection, Protection & Hydrant System & Fire Door





## CLIENT LIST (DHAKA)

SL	Client	Address	Project Type
55	Fashion Steps Ltd.(Fashion Step Group)	Tilargati Road, Satish, Tongi, Gazipur	Central Fire Detection, Protection & Hydrant System.& Fire Door
56	Billah Resources Ltd.(Fashion Step Group)	17/1, Khataldia, Squib Road, Nishad Nagar, Tongi, Gazipur	Central Fire Detection System.
57	Max Sweater (BD) Ltd.	24,26 Dighi Borabo, Tarabo, Rupganj, Narayanganj.	Central Fire Detection System
58	MNS Garments Printing	H-12, R-3, Sumonertek, Rajbari, Dhour, Turag, Dhaka-1230.	Central Fire Detection, Protection, Hydrant System & Lightning Protection System (LPS)
59	Yunusco BD Ltd.	Adamjee, Narayanganj.	Fire Protection & Sprinkler System.
60	T-Design Sweater Ltd.	Nilnagar, Konabari, Gazipur.	Central Fire Detection System & Fire Protection System, Fire Door, LPS & SLD.
61	Unisense Apparels Ltd.	Ansar Road, Sreepur	Central Fire Detection System.
62	Esprit Apparels Ltd.	Kaliakair, National University, Gazipur Sadar, Gazipur.	Central Fire Detection System, Fire Protection System.& Fire Door.
63	Aman Graphics & Designs Ltd.(Unifill Group)	Singair Road, Hemayetpur	Fire Door Supply and Installation for Full Project.
64	Rupayan City Uttara (Rupayan Group)	Rupayan City Uttara, Nolbhog, Sector-12, Uttara, Dhaka	Central Fire Detection System & Fire Protection System.
65	Masihata Business Tower	Jashimuddin, Uttara.	Central Fire Detection System & Fire Protection System.
66	Elegant Leavender (Elesan) Group	Gulshan-2	Central Fire Detection, Protection & Sprinkler System.
67	Janata Jute Mills Ltd.(Akij Group)	Polash, Ghorashal, Narsingdi	Central Fire Detection & Alarm System, Central Fire Protection System
68	Janata Jute Mills Ltd.(Akij Group)	Boalmari, Faridpur	Central Fire Detection & Alarm System, Central Fire Protection System
69	Sadat Jute Industries Lld.(Akij Group)	Jafarpur, Debidwar, Cumilla.	Central Fire Detection System & Fire Protection System, Fire Sprinkler System.
70	Apex Footwear Ltd. Unit-2	Chandhura, Kaliakair, Gazipur	Central Fire Detection & Alarm System, Central Fire Protection System.
71	NPM Apparels Limited	Plot 1, Marium village, Aral Bazar, Kapasia, Gazipur, Dhaka.	Central Fire Detection System & Fire Protection System.
72	Confidence Infrastructure Ltd.	Barishal Silo, 30 Godown, Barishal.	Central Fire Detection System & Fire Protection System.
73	Abdul Monem Group	Kawran Bazar, Dhaka.	Central Fire Detection System & Fire Protection System (FPS) / Hydrant & Sprinkler System.
74	Well Accessories Ltd.	Baniarchala, P.O.-Bhabanipur, Mirzapur, Gazipur,	Central Fire Detection System, Fire Protection System & Sprinkler System
75	Experience Clothing Co. Ltd.	Plot # 72 & 82, Ganakbari, DEPZ Dhaka	Fire Protection System.
76	Harry Fashion Ltd.	Varo Doba, Valuka, Mymensingh	Fire Protection System.
77	Bottoms Gallery (Pvt.) Ltd.	Chandana, Joydebpur, Gazipur Sadar, Gazipur.	Central Fire Detection System & Fire Protection System
78	Colour & Co. Ltd.	Tapir Bari, Tengra, Sreepur, Gazipur.	Central Fire Detection System, Fire Protection System & Sprinkler System.
79	Wendler Interlining Bangladesh Limited.	Trishal, Mymensingh.	Central Fire Detection System & Fire Protection System.
80	Banex Apparel Ltd.	473, North Ibrahimpur, Shreepur, Kafrul, Cantonment, Dhaka	Central Fire Detection System & Fire Protection System, Sprinkler System.
81	Yongtai Industries Bangladesh Ltd.	Tarabo, Narayanganj	Central Fire Detection System & Fire Door

## CLIENT LIST (CHATTOGRAM)

SL	Client	Address	Project Type
1	Well Composite Knit Ltd.	Outer Signal-Kalurghat, Chattogram.	Central Fire Detection System, Fire Protection System & Sprinkler System
2	Lubricants Asia Ltd - FUCHS	BSCIC Industrial Estate, 4219 Sagorika Rd, Chattogram 4219	Central Fire Detection and Alarm System
3	Paxar Bangladesh Ltd.	Plot: B-24, Plot-30-B, KEPZ, Anwara, Chattogram, Bangladesh.	Central Fire Detection System, Fire Protection System & Fire Sprinkler System.
4	Karnaphuly Tunnel	Anwara Upazila, Chattogram Division, Bangladesh	FM-200 Suppression System and Foam Suppression System .
5	HS Composite Textiles Ltd.	Chaturi, Chowmohuni, Anwara, Chattogram.	Central Fire Detection System, Fire Protection System & LPS
6	Pahartoli Spinning & Hosiery Mills Ltd. (Ispahani Group)	Ispahani Complex, North Pahartali, Chattogram-4202	Central Fire Detection System & Fire Protection System.
7	Clifton Textile & Apparels Ltd.	Nasirabad I/A, Baized, Chattogram.	Fire Detection System Supply & Installation.
8	Young One-KSI 6th Phase	KEPZ-Anwara, Chattogram.	Fire Hydrant System Supply & Installation.
9	Maf Shows Ltd.	Outer Signal-Kalurghat, Chattogram.	Lightning Protection System (LPS) Supply & Installation
10	SQ Electricals Ltd.	Zone-2A Mirsharai Economic Zone, Chattogram	Fire Hydrant System Supply & Installation.
11	Pacific Jeans Ltd.	CEPZ-Chattogram	Fire-Hydrant System Supply
12	Consort Flexi Pack Ltd.	C & B Kalurghat-Chattogram	Fire Hydrant and Fire Detection System Supply & Installation.
13	Albion Specialized Pharmaceuticals Ltd.	Sitakunda-Chattogram, Bangladesh.	Fire Hydrant System Supply & Installation.
14	RDS Tower [G+18]	Chowdhury Hat, Hathazari, Chattogram	Fire Hydrant and Fire Detection System Supply & Installation.
15	Sonnet Fashion Ltd.	Outer Signal-Kalurghat, Chattogram.	Fire Hydrant System and Fire Detection System Supply & Installation.
16	Karnaphuli Sportswear Ind. Ltd. (Youngone)	Sector-7, CEPZ, Chattogram	Fire Hydrant System Supply & Installation.
17	Azim Group	C & B Kalurghat-Chattogram	Fire Hydrant System Supply & Installation.
18	Karnaphuli Polyester Product Co. Ltd-KPP-2 & 3.	KEPZ-Anwara, Chattogram.	Lightning Protection System (LPS) Supply & Installation.
19	Surma Garment Washing & Finishing Co. Ltd.	Plot #22, Sector #02, CEPZ, Chattogram	Fire Sprinkler System, Hydrant System Supply & Installation.
20	Banskhali 1320 MW (SSPL) Coal Power Plant	Banskhali-Chattogram	Fire Detection System Installation Work (Dormitory Building).
21	Jumairah Grand Taj (G+18)	Nasirabad-R/A-Chattogram	Fire-Hydrant System Supply & Installation.
22	Park BD Ltd. (Unit-2)	KEPZ-Chattogram	Fire-Hydrant System Supply.
23	City Homes Ltd. (G+16)	Chawkbazar-Chattogram	Fire-Hydrant System Supply & Installation.
24	Gaya Product Development Co. Ltd.	KEPZ-Chattogram	Fire-Hydrant System Supply & Installation.
25	Universal Jeans Ltd.	CEPZ-Chattogram	Fire Hydrant System Accessories Supply.
26	Smart Group	Nasirabad I/A, Bayzid Thana Road Bayzid, Chattogram-4210, Bangladesh	Fire Protection System Accessories Supply.
27	Nine 2 Nine Intimates Ltd.(Yunusco Group)	C & B Kalurghat	Fire Sprinkler System, Hydrant System & CFDS System Supply & Installation.
28	KEPZ Trust Hospital	Plot #13, KEPZ-Anwara, Chattogram	Fire Hydrant System Supply & Installation.

 compliancebd.com  
 /compliancebdltd  
 /compliancebdltd  
 /company/compliancebd



**COMPLIANCE BD LTD.**  
*One Stop Engineering Solution*



**Corporate Office :**  
383 Razzak Plaza (13<sup>th</sup> Floor), Moghbazar,  
Dhaka-1217, Bangladesh.

**Chattogram Office:**  
Laila Garden (4<sup>th</sup> Floor), Sharaipara, 1750/A,  
P.C Road, Chattogram, Bangladesh



+88-02-222228875



+88 01911-643816

+88 01766-670693



info@compliancebd.com  
compliancebd01@gmail.com



www.compliancebd.com